

## CONCEPT LINE DISHWASHERS



### DISHWASHING CONCEPT LINE

Glasswashers	164
Front loading dishwashers	165
Front loading dishwasher - big door	166
Pass-through dishwashers	167
Delivery - sorting tables	168
Accessories	170

#### Water softener:

All glass / dishwashers should be connected to a treated water supply when the local supply is over 10 HF / 6 HD.

#### Water connection:

It is advisable to introduce sanitary water in the dishwashers, with a temperature of 50 - 60 °C

#### Water pressure:

Minimum: 2 bar = 2 Kg / cm<sup>2</sup>  
Maximum: 4 bar = 4 Kg / cm<sup>2</sup>

# CONCEPT LINE DISHWASHERS

## GLASS - WASHERS

### Standard features:

Tank with rounded corners.  
 Built-in rinse water boiler. Automatic rinse dispenser.  
 Wash timer 0 ÷ 120"  
 Thermostatically adjusted: wash 60 °C, and rinse 90 °C.  
 Safety thermostat.  
 Safety switch for door opening (except LVC-12 model).  
 Equipped with 2 baskets and 1 cutlery container.  
 Electrical connection: 230 V - 1+N+T



Model	Reference	Production Pieces/h	Basket mm	Equipment (*)	Power KW	Dimensions mm	
LVC-12	1210202500	1,200 - Ø19	350x350	1-P-S	2,66	430x475x650	
LVC-15	1210202600	1,500 - Ø19	350x350	2-F-P-S	2,66	430x475x650	
LVC-21	1210202700	2,100 - Ø27	400x400	3-F-G-Z	3,06	470x520x720	

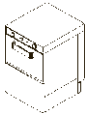

### (\*) TANKS AND BOILERS

- 1 :** Tank: Power: 1 KW - Capacity: 11 litres  
 Boiler: Power: 2.4 KW - Consumption: 2 litres/rinse
- 2 :** Tank: Power: 2 KW - Capacity: 11 litres  
 Boiler: Power: 2.4 KW - Consumption: 2 litres/rinse
- 3 :** Tank: Power: 2 KW - Capacity: 15 litres  
 Boiler: Power: 2.8 KW - Consumption: 2.5 litres/rinse

### (\*) EQUIPMENT

- F :** Optional cold rinse at the end of the cycle.
- P :** Capacity for Dishes Ø 19 cm.
- G :** Capacity for Dishes Ø 27 cm.
- S :** One supplement for saucers.
- Z :** One supplement for dishes.

## GLASS - WASHER WITH DRAIN PUMP

### Specific features:

Drain pump and drainage cycle.  
 Capacity for Dishes Ø 27 cm.  
 Equipped with 2 baskets, 1 cutlery container and supplement for dishes.  
 Fixed wash cycle 120".  
 Tank: Power: 2 KW - Capacity: 15 litres  
 Boiler: Power: 2.8 KW - Consumption: 2.5 litres/rinse  
 Optional cold rinse at the end of the cycle.  
 Electrical connection: 230 V - 1+N+T



Model	Reference	Production Pieces/h	Basket mm	Equipment (*)	Power KW	Dimensions mm	
LVC-21 B	1210202800	2,100 - Ø27	400x400	3-F-G-Z	3,13	470x520x720	



FRONT LOADING DISHWASHERS

Standard features:

- Rotating wash and rinse.
- Tank with rounded corners.
- Capacity: 25 litres.
- Wash water heated by means of shielded elements on the tank : 2.8 KW.
- Built-in rinse water boiler. Consumption: 2.7 litres/rinse.
- Automatic rinse dispenser.
- Thermostatically adjusted: wash 60 °C, and rinse 90 °C.
- Safety thermostat.
- Safety switch for door opening.
- Capacity for dishes Ø 32 cm.
- Basket size: 500 x 500 mm.



Model	Reference	Production Dishes/h	Technical features (*)	Equipment (**)	Power KW	Dimensions mm	
FI-30	1210305100	360	1-M	S	3,45	600x600x820	
FI-48	1210305200	540	2-M	X-L	3,45	600x600x820	
FI-64	1210305500	720	3-T	X-L	6,65	600x600x820	

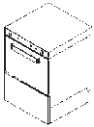

(\*) TECHNICAL FEATURES:

- 1 : Wash cycle: adjustable : 0-240".
- 2 : Wash cycles: 120" and 180" fixed.
- 3 : Wash cycles: 90" and 180" fixed.
- M : Electrical connection: 230 V - 1+N+T - Boiler: 2,8 KW.
- T : Electrical connection: 400 V - III+ N+T - Boiler: 6 KW.

(\*\*) EQUIPMENT:

- S : 1 base basket CT-10 + 1 basket for dishes CP-16/18 and 1 cutlery container.
- X : 1 base basket CT-10 + 1 basket for dishes CP-16/18 and 4 cutlery container.
- L : Filters and trays in the wash tank.

FRONT LOADING DISHWASHERS WITH DRAIN PUMP

Specific features:

Drain pump (70 W) and drainage cycle.

Model	Reference	Production Dishes/h	Cycles Time (sec.)	Electrical connection	Power KW Boiler	Total	Dimensions mm	
FI-48 B	1210305300	540	120"-180"	230V-1+N+E	2,80	3,52	600x600x820	
FI-64 B	1210305600	720	90"-180"	400V-3+N+E	6,00	6,72	600x600x820	

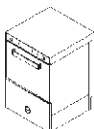

# CONCEPT LINE DISHWASHERS

## FRONT LOADING DISHWASHER WITH BIG DOOR

**Model with capacity for dishes Ø 42 cm and for self-service trays.**

**Ergonomic and very easy to use.**

- Rotating wash and rinse.
- Heated by means of shielded elements.
- Built-in rinse water boiler.
- Automatic rinse dispenser.
- Thermostatically adjusted: wash 60 °C, and rinse 90 °C.
- Safety thermostat.
- Thermometers for wash and rinse water temperature.
- Safety switch for door opening.
- Basket size: 500 x 500 mm.
- Special tank size for trays.
- Tank with rounded corners.
- Tank capacity: 25 litres.
- Water consumption: 2.7 litres / rinse.
- Wash cycles: 90" and 180" fixed.

**Equipment:**

1 base basket CT-10, 1 basket for dishes CP-16/18, 1 basket for trays CB-7 and 4 cutlery containers.

Connection: 400 V - 3+N+T



Model	Reference	Production Dishes/h	Cycles Time (sec.)	Electrical connection	Power KW		Dimensions mm	
					Boiler	Total		
FI-72	1210305700	720	90"-180"	400V-3+N+E	6,00	6,65	600x600x1,200	



**ELECTRIC PASS-THROUGH DISHWASHERS**

**Standard features:**

- Capacity for dishes Ø 42 cm.
- The hood rises easily, with compensation system.
- Upper and lower rotating wash and rinse system.
- Heated by means of shielded elements.
- Tank with 4.5 kW heating element.
- Tank capacity: 45 litres.
- Filters and trays in the wash tank.
- Thermostatically adjusted:  
wash temperature 60 °C and rinse temperature 90 °C.
- Safety thermostat.
- Automatic rinse dispenser.
- Boiler with stainless steel heating elements for the water of the rinse. Safety thermostat for the rinse.
- Water consumption: 3 litres by rinse.
- Pilots (FI-80) or thermometers (FI-100) for wash and rinse temperatures, depending on the model.
- Safety switch for hood opening.
- Electrical connection: 400 V - 3+N+T



FI-100 with entry - exit tables

Model	Reference	Production Dishes/h	Technical features (*)	Equipment (**)	Power KW	Dimensions mm	
FI-80	1210307400	800	1-C-F	S	11,10	675x675x1,400	
FI-100	1210307100	900	2-E-P	X-T	14,70	675x675x1,400	



**ELECTRIC PASS-THROUGH DISHWASHERS WITH DRAIN PUMP**

**Specific features:**

Drain pump (90 W) and drainage cycle.

Model	Reference	Production Dishes/h	Technical features (*)	Equipment (**)	Power KW		Dimensions mm	
					Boiler	Total		
FI-100 B	1210307191	900	2-E-P	X-T	9,00	14,79	675x675x1,400	



**(\*) TECHNICAL CHARACTERISTICS**

- 1: One wash pump for lower and upper systems, 590 W.
- 2: Two independent wash pumps for lower and upper systems, 590 W each.
- C: Boiler with 6 kW power.
- E: Boiler with 9 kW power.
- F: Wash cycles: 90" y 180".
- P: Wash cycles: 55", 75", 120", continuous washing position and stand-by position.

**(\*\*) EQUIPMENT**

- T: Analogic Thermometers for the wash and rinse water.
- S: 1 basket CT-10 + 1 basket for dishes CP-16/18 + 2 cutlery containers.
- X: 1 basket CT-10 + 1 basket for dishes CP-16/18 + 8 cutlery containers.

# PREWASHING TABLES FOR PASS-THROUGH DISWASHERS

## PRE WASHING TABLES

Manufactured for the pass-through dishwashers:  
AD-90, AD-120, AD-120 ECO, FI-80 , FI-100



*MFDB-1200 I model,  
with guides, lower rack,  
sink and shower tap*

Model	Reference	Situation of the table	Equipment Features	Dimensions mm	
<b>RIGHT TABLE</b>	1210307515	RIGHT	- Lower rack	650x655x900	
<b>LEFT TABLE</b>	1210307516	LEFT			
<b>RIGHT TABLE - REAR GUARD</b>	1210307517	RIGHT	- Rear guard - Lower rack	650x655x900	
<b>LEFT TABLE - REAR GUARD</b>	1210307518	LEFT			
<b>RIGHT TABLE - ECO</b>	1210307519	RIGHT	- Hole for generator chimney	650x655x900	
<b>LEFT TABLE - ECO</b>	1210307520	LEFT			
<b>RIGHT TABLE - ECO - R. GUARD</b>	1210307521	RIGHT	- Rear guard - Hole for generator chimney	650x655x900	
<b>LEFT TABLE - ECO - R. GUARD</b>	1210307522	LEFT			
<b>MFDB-700 D</b>	2151502314	RIGHT	- Rear guard - Sink - Shower tap - Lower rack	700x700x900	
<b>MFDB-700 I</b>	2151502315	LEFT			
<b>MLB-1200 D</b>	2151502300	RIGHT	- Rear guard - Lower rack - Guides for baskets	1,200x700x900	
<b>MLB-1200 I</b>	2151502301	LEFT			
<b>MLB-1200 ECO/D</b>	2151502306	RIGHT	- Rear guard - Lower rack - Guides for baskets - Hole for generator chimney	1,200x700x900	
<b>MLB-1200 ECO/I</b>	2151502307	LEFT			
<b>MFDB-1200 D</b>	2151502316	RIGHT	- Rear guard - Sink - Shower tap - Lower rack - Guides for baskets	1,200x700x900	
<b>MFDB-1200 I</b>	2151502317	LEFT			
<b>MFDB-1500 D</b>	2151502302	RIGHT	- Rear guard - Sink - Shower tap - Lower rack - Guides for baskets	1,500x700x900	
<b>MFDB-1500 I</b>	2151502303	LEFT			

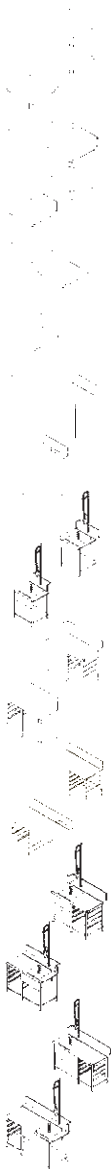

## DELIVERY/SORTING TABLES FOR PASS-THROUGH DISWASHERS

### DELIVERY / SORTING TABLES

Manufactured for the pass-through dishwashers:  
AD-90, AD-120, AD-120 ECO, FI-80 , FI-100

- Rear guard in all the models.
- Waste disposal.
- Space for the trash bin.
- Tables with sink built-in shower tap.

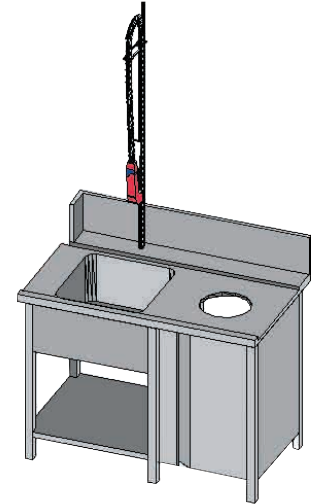

*MFDP-1200-D model, with sink, shower tap, and closed space for trash bin.*

Model	Reference	Situation of the table	Housing for bin	Equipment Features	Dimensions mm	
MLH-1200 D	2151502318	RIGHT	OPEN	- Lower rack	1,200x700x900	
MLH-1200 I	2151502319	LEFT				
MLP-1200 D	2151502320	RIGHT	With DOOR	- Lower rack	1,200x700x900	
MLP-1200 I	2151502321	LEFT				
MFDH-1200 D	2151502322	RIGHT	OPEN	- Sink - Shower tap - Lower rack	1,200x700x900	
MFDH-1200 I	2151502323	LEFT				
MFDP-1200 D	2151502324	RIGHT	With DOOR	- Sink - Shower tap - Lower rack	1,200x700x900	
MFDP-1200 I	2151502325	LEFT				
MFDH-1500 D	2151502326	RIGHT	OPEN	- Sink - Shower tap - Lower rack	1,500x700x900	
MFDH-1500 I	2151502327	LEFT				
MFDP-1500 D	2151502328	RIGHT	With DOOR	- Sink - Shower tap - Lower rack	1,500x700x900	
MFDP-1500 I	2151502329	LEFT				
MFDH-1800 D	2151502304	RIGHT	OPEN	- Sink - Shower tap - Lower rack - Guides for baskets	1,800x700x900	
MFDH-1800 I	2151502305	LEFT				
MFDP-1800 D	2151502330	RIGHT	With DOOR	- Sink - Shower tap - Lower rack - Guides for baskets	1,800x700x900	
MFDP-1800 I	2151502331	LEFT				

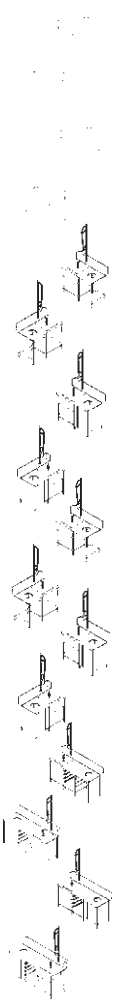

*MFDH-1800-I model, with sink, shower tap, waste disposal, rear guard and guides for baskets*



## ACCESSORIES

### SINKS WITH SPACE FOR DISHWASHER

Sink with draining board.  
Sink dimensions: 500 x 500 x 300 mm.  
Lower shelf under sink.  
Housing for the dishwasher under draining board.  
Space for dishwashers 600 x 600 mm,  
820÷850 mm high.  
Adjustable legs.



**FBL-127 D**

Model	Reference	Characteristics	Dimensions mm	
<b>FBL-127 D</b>	2111123103 +	Draining board and housing on the <b>RIGHT</b>	1,200x700x850	
	2111222120			
<b>FBL-127 I</b>	2111123104 +	Draining board and housing on the <b>LEFT</b>	1,200x700x850	
	2111222120			

### STAND FOR FRONT LOADING DISHWASHER

Space for baskets 500 x 500 mm.  
Capacity for 3 baskets height 110 mm.  
For the front loading dishwashers, except "72" models.



**AD-48 model  
over stand**



Model	Reference	Characteristics	Dimensions mm	
<b>STAND</b>	1210305185	Capacity for 3 baskets 500x500x110 mm	600x600x400	

ASSEMBLY MODES FOR PASS-THROUGH DISHWASHERS



*Linear assembly  
with entry exit tables*



*Pass-through dishwasher with  
prewashing table MFDB-700 I  
and exit table*



*Assembly in corner  
with entry exit tables*



*AD-120 ECO with tables*



*FI-80 Pass-through dishwasher with  
prewashing table MFDB-1500 I and exit table MLB-1200 D*

