

FØYNLAND
STORKJØKKEN AS

DISHWASHING



ADVANCE LINE DISHWASHING



DISHWASHING ADVANCE LINE

Dishwashing - COMPLET Series	147
CLINIC dishwashing - HY Series	149
Glasswashers	150
Front loading dishwashers	152
Front loading dishwasher - big door	154
Pass-through dishwashers	155
Gas dishwashers "ECO"	156
Delivery - sorting tables	158
Prewashing tables - COMPLET Series	160
Accessories	161

Water softener:

All glass / dishwashers should be connected to a treated water supply when the local supply is over 10 HF / 6 HD.

Water connection:

It is advisable to introduce sanitary water in the dishwashers, with a temperature of 50 - 60 °C

Water pressure:

Minimum: 2 bar = 2 Kg / cm²
Maximum: 4 bar = 4 Kg / cm²



At Fagor Industrial, we have developed a new range of dishwashers, the **ADVANCE** Line.

These dishwashers are unique thanks to their modern lines and finishes, and their electronic operation.

The **ADVANCE** Line operates electronically for greater ease of use and more intuitive functions.

Thanks to the digital display, the user can see the water temperatures during all wash stages, including rinsing and washing.

A very important aspect for users and technicians alike is the error and malfunction diagnostic system included in the **ADVANCE** machines.

The **ADVANCE** Line includes the following models:

- standard
- with drain pump and programme (B)
- with built-in water softener and salt regeneration programme (D)
- with detergent dispenser (DD)



All the machines included in this range are equipped with a anti-return protection system.

This prevents wastewater from returning to the hydraulic net, guaranteeing maximum hygiene during all processes.

These dishwashers also include a thermo stop function that guarantees a minimum rinsing water temperature of 85°C (the minimum temperature that prevents bacterial growth).

And the top of the line is the **ADVANCE COMPLET** that, apart from all the features of the other models, also includes double skinned with insulation, for improved soundproofing and temperature maintenance inside the machine.

The **ADVANCE** Line is available in glass washers, front-loading dishwashers with standard or large doors, and pass-through dishwashers, in gas and electric versions.

ADVANCE COMPLET LINE DISHWASHERS

DISHWASHERS WITH DOUBLE SKINNED AND MORE FEATURES

The **ADVANCE** Line presents its **ADVANCE COMPLET** version, the best-equipped machines for each range, with more features and a double panel system.

Double rotating wash and rinse systems, above and below.

Rounded tank for easy cleaning and draining.

Double skinned with insulation for improved soundproofing and reduced loss of heat inside the machine.

Heating elements in tank and boiler.

Electronic operation.

Thermostatic temperature control: washing at 60°C and rinsing at 90°C.

Thermo stop system that guarantees minimum rinsing temperature of 85°C.

Digital wash and rinse temperature display.

Security thermostats.

Self diagnostic system.

Anti - return protection system.

Drain pump and drainage cycle

Security switch on door or hood.

Equipped with rinse dispenser.

Equipped with detergent dispenser.

GLASS-WASHERS ADVANCE COMPLET

Specific features:

Basket: 400 x 400 mm.

Capacity for dishes de Ø 27 cm.

Wash cycles: 90" - 120" - 180"

Optional cold rinse at the end of the cycle.

Tank: Power: 2 KW - Capacity: 15 litres

Boiler: Power: 2,8 KW - Consumption: 2,5 litres/rinse

Electrical connection: 230 V - 1+N+E

Equipment: 2 Baskets,
1 Cutlery container and
1 supplement for dishes



Model	Reference	Production Pieces/h	Basket mm	Electrical connection	Power KW	Dimensions mm	
AD-21 C	1210202878	2,100 - Ø27	400x400	230V-1+N+T	3,13	510x545x720	



ADVANCE COMPLET LINE DISHWASHERS

FRONT LOADING DISHWASHERS ADVANCE COMPLET

Specific features:

Basket: 500 x 500 mm.
Capacity for dishes de Ø 32 cm.
Wash cycles: 60" - 90" - 180"

Tank: Power: 2.8 KW - Capacity: 25 litres
Boiler: Consumption: 2,7 litres/rinse

Equipment: 1 CT-10 Base Basket,
1 CP-16/18 Basket for dishes and
4 Cutlery containers



Model	Reference	Production Dishes/h	Cycles Time (sec.)	Electrical connection	Power KW		Dimensions mm	
					Boiler	Total		
AD-48 C	1210305378	540	60"-90"-180"	230V-1+N+T	2,80	3,52	640x625x820	
AD-64 C	1210305678	720	60"-90"-180"	400V-3+N+T	6,00	6,72	640x625x820	

PASS-THROUGH DISHWASHERS ADVANCE COMPLET

Specific features:

Basket: 500 x 500 mm.
Capacity for dishes de Ø 42 cm.

Two independent wash pumps for lower and upper systems,
590 W each.

Wash cycles: 55", 75", 120", continuous washing position and
stand-by position.

Tank: Power: 4,5 KW - Capacity: 45 litres
Boiler: Power: 12 KW Consumption: 3 litres/rinse

Electrical connection: 400 V - 3+N+T

Equipment: 1 CT-10 Base Basket,
2 CP-16/18 Basket for dishes and
8 Cutlery containers



Model	Reference	Production Dishes/h	Cycles Time (sec.)	Electrical connection	Power KW		Dimensions mm	
					Boiler	Total		
AD-120 C	1210307278	1.200	55-75-120-C-Sby	400V-3+N+T	12,00	17,79	675x675x1,400	

ADVANCE HYGIENIC LINE DISHWASHERS

HYGIENIC DISHWASHERS

Dishwashers with double skinned and insulation.

- Rotating wash and rinse system.
- Heated by means of shielded elements.
- Boiler with stainless steel heating elements for the water of the rinse.
- Automatic rinse **dispenser**.
- Automatic wash product **doser**.
- Thermostatically adjusted:
 - wash temperature 60 °C and rinse temperature 90 °C.
- Digital display for rinsing and washing temperature.
- Thermo-stop** rinse device at 83 °C.
- Safety thermostats for wash and rinse.
- Drain pump** and drainage cycle.
- Filters and trays in the wash tank.
- Pressure pump for rinse.
- Break tank system.**
- Booster pump.**
- Safety system** that assures water doesn't enter during rinse.
- Safety switch** for door opening.
- Adjustable legs.

Important:

It is advisable to introduce sanitary water in the dishwasher, with a temperature of 50 - 60 °C



Model	Reference	Production Dishes/h	Equipment Features (*)	Voltage	Power KW	Dimensions mm	
AD-48 HY	1210305374	540	1-C-A-S	230V-1+N+E	3,52	640x625x820	
AD-64 HY	1210305674	720	1-E-A-S	400V-3+N+E	6,72	640x625x820	
AD-120 HY	1210307274	1.200	2-H-B-Z	400V-3+N+E	17,79	675x675x1.400	

(*) TECHNICAL CHARACTERISTICS

- 1:** One wash pump for lower and upper systems, 590 W.
- 2:** Two independent wash pumps for lower and upper systems, 590 W each.
- C:** Power: Tank: 2,8 KW - Boiler: 2,8 KW
- E:** Power: Tank: 2,8 KW - Boiler: 6,0 KW
- H:** Power: Tank: 4,5 KW - Boiler: 12,0 KW
- A:** Wash cycles: 60", 90" and 180".
- B:** Wash cycles: 55", 75", 120", stand by and continuous washing program

(**) EQUIPMENT

- S:** 1 basket-base CT-10 + 1 basket for dishes CP-16/18 + 4 cutlery containers
- Z:** 1 basket-base CT-10 + 2 basket for dishes CP-16/18 + 8 cutlery containers

ADVANCE LINE DISHWASHERS

The **ADVANCE Series** presents these features:

- Double rotating wash and rinse systems, above and below.
- Rounded tank for easy cleaning and draining.
- Heating elements in tank and boiler.
- Electronic operation.
- Thermostatic temperature control: washing at 60°C and rinsing at 90°C.
- Thermo stop system that guarantees minimum rinsing temperature of 85°C.
- Digital wash and rinse temperature display.
- Security thermostats.
- Self diagnostic system.
- Anti - return protection system.
- Security switch on door or hood.
- Equipped with rinse dispenser.

GLASS - WASHERS

Standard features:

- Wash cycles: 90" - 120" - 180"
- Tank with rounded corners.
- Double skinned on door.
- Built-in rinse water boiler. Automatic rinse dispenser.
- Thermostatically adjusted: wash 60 °C, and rinse 90 °C.
- Digital display for rinsing and washing temperature.
- Thermo stop system.
- Self diagnostic system.
- Anti - return protection.
- Safety thermostat.
- Safety switch for door opening.
- Equipped with 2 baskets and 1 cutlery container.
- Electrical connection: 230 V - 1+N+T



Model	Reference	Production Pieces/h	Basket mm	Equipment (*)	Power KW	Dimensions mm	
AD-15	1210202605	1,500 - Ø19	350x350	2-F-P-S	2,66	430x475x650	
AD-21	1210202705	2,100 - Ø27	400x400	3-F-G-Z	3,06	470x520x720	

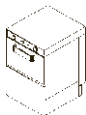

(*) TANKS AND BOILERS

- 1:** Tank: Power: 1 KW - Capacity: 11 litres
Boiler: Power: 2.4 KW - Consumption: 2 litres/rinse
- 2:** Tank: Power: 2 KW - Capacity: 11 litres
Boiler: Power: 2.4 KW - Consumption: 2 litres/rinse
- 3:** Tank: Power: 2 KW - Capacity: 15 litres
Boiler: Power: 2.8 KW - Consumption: 2.5 litres/rinse

(*) EQUIPMENT

- F:** Optional cold rinse at the end of the cycle.
- P:** Capacity for Dishes Ø 19 cm.
- G:** Capacity for Dishes Ø 27 cm.
- S:** One supplement for saucers.
- Z:** One supplement for dishes.

ADVANCE LINE DISHWASHERS

GLASS - WASHERS WITH SOFTENER

Specific features:

Built in softener.
Timer for regeneration cycle.

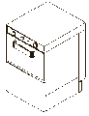

Model	Reference	Production Pieces/h	Basket mm	Equipment (*)	Power KW	Dimensions mm	
AD-21 D	1210203405	2,100 - Ø27	400x400	3-F-G-Z	3,06	470x520x720	

GLASS - WASHER WITH DRAIN PUMP

Specific features:

Drain pump and drainage cycle.



Model	Reference	Production Pieces/h	Basket mm	Equipment (*)	Power KW	Dimensions mm	
AD-21 B	1210202805	2,100 - Ø27	400x400	3-F-G-Z	3,13	470x520x720	

GLASS - WASHERS WITH DETERGENT DOSER

Specific features:

Detergent doser.



Model	Reference	Production Pieces/h	Basket mm	Equipment (*)	Power KW	Dimensions mm	
AD-21 DD	1210202776	2,100 - Ø27	400x400	3-F-G-Z	3,13	470x520x720	

ADVANCE LINE DISHWASHERS

FRONT LOADING DISHWASHERS

Standard features:

Wash cycles: 60" - 90" - 180".
 Rotating wash and rinse.
 Tank with rounded corners. Double skinned on door.
 Capacity: 25 litres.
 Wash water heated by means of shielded elements on the tank : 2.8 KW.
 Built-in rinse water boiler. Consumption: 2.7 litres/rinse.
 Filters and trays in the wash tank.
 Automatic rinse dispenser.
 Thermostatically adjusted: wash 60 °C, and rinse 90 °C.
 Safety thermostat. Thermo stop system.
 Digital display for rinsing and washing temperature.
 Self diagnostic system.
 Anti - return protection.
 Safety switch for door opening.
 Capacity for dishes Ø 32 cm.
 Basket size: 500 x 500 mm.



Model	Reference	Production Dishes/h	Technical features (*)	Equipment (**)	Power KW	Dimensions mm	
AD-48	1210305205	540	M	X-L	3,45	600x600x820	
AD-64	1210305505	720	T	X-L	6,65	600x600x820	

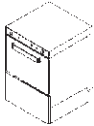

(*) TECHNICAL FEATURES:

M : Electrical connection: 230 V - 1+N+T - Boiler: 2,8 KW.
T : Electrical connection: 400 V - III+ N+T - Boiler: 6 KW.

(**) EQUIPMENT:

X : 1 base basket CT-10 + 1 basket for dishes CP-16/18 and 4 cutlery container.

L : Filters and trays in the wash tank.

FRONT LOADING DISHWASHERS WITH SOFTENER

Specific features:

Built in descaling unit.
 Timer for regeneration cycle.



Model	Reference	Production Dishes/h	Cycles Time (sec.)	Electrical connection	Power KW		Dimensions mm	
					Boiler	Total		
AD-48 D	1210305275	540	60"-90"-180"	230V-1+N+T	2,80	3,45	600x600x820	
AD-64 D	1210305572	720	60"-90"-180"	400V-3+N+T	6,00	6,65	600x600x820	

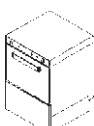

ADVANCE LINE DISHWASHERS

FRONT LOADING DISHWASHERS WITH DRAIN PUMP

Specific features:

Drain pump (70 W) and drainage cycle.

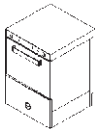

Model	Reference	Production Dishes/h	Cycles Time (sec.)	Electrical connection	Power KW		Dimensions mm	
					Boiler	Total		
AD-48 B	1210305305	540	60"-90"-180"	230V-1+N+T	2,80	3,52	600x600x820	
AD-64 B	1210305605	720	60"-90"-180"	400V-3+N+T	6,00	6,72	600x600x820	

FRONT LOADING DISHWASHERS WITH DETERGENT DOSER

Specific features:

Built-in detergent doser.

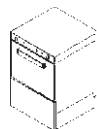

Model	Reference	Production Dishes/h	Cycles Time (sec.)	Electrical connection	Power KW		Dimensions mm	
					Boiler	Total		
AD-48 DD	1210305276	540	60"-90"-180"	230V-1+N+T	2,80	3,45	600x600x820	
AD-64 DD	1210305571	720	60"-90"-180"	400V-3+N+T	6,00	6,65	600x600x820	

ADVANCE LINE DISHWASHERS

FRONT LOADING DISHWASHER WITH BIG DOOR

Model with capacity for dishes Ø 42 cm and for self-service trays.

Ergonomic and very easy to use.

- Rotating wash and rinse.
- Heated by means of shielded elements.
- Built-in rinse water boiler.
- Double skinned on door.
- Automatic rinse dispenser.
- Thermostatically adjusted: wash 60 °C, and rinse 90 °C.
- Thermo stop system.
- Self diagnostic system.
- Anti - return protection.
- Safety thermostat.
- Digital display rinsing for and washing temperature.
- Safety switch for door opening.
- Basket size: 500 x 500 mm.
- Special tank size for trays.
- Tank with rounded corners.
- Tank capacity: 25 litres.
- Water consumption: 2.7 litres / rinse.
- Wash cycles: 60" - 90" and 180" fixed.

Equipment:

1 base basket CT-10, 1 basket for dishes CP-16/18, 1 basket for trays CB-7 and 4 cutlery containers.

Connection: 400 V - 3+N+T



Model	Reference	Production Dishes/h	Cycles Time (sec.)	Electrical connection	Power KW		Dimensions mm	
					Boiler	Total		
AD-72	1210305705	720	60"-90"-180"	400V-3+N+T	6,00	6,65	600x600x1,200	

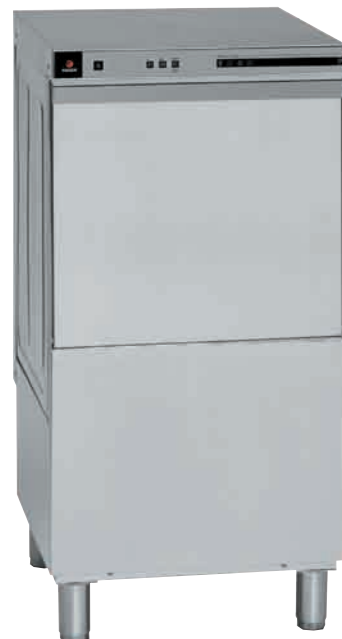

ELECTRIC PASS-THROUGH DISHWASHERS

Standard features:

- Capacity for dishes Ø 42 cm.
- Wash cycles: 55", 75", 120", continuous washing position and stand-by position.
- The hood rises easily, with compensation system.
- Upper and lower rotating wash and rinse system.
- Heated by means of shielded elements.
- Tank with 4.5 kW heating element.
- Tank capacity: 45 litres.
- Filters and trays in the wash tank.
- Thermostatically adjusted:
wash temperature 60 °C and rinse temperature 90 °C.
- Thermo stop system.
- Self diagnostic system.
- Anti - return protection.
- Safety thermostat.
- Digital display for rinsing and washing temperature.
- Automatic rinse dispenser.
- Boiler with stainless steel heating elements for the water of the rinse. Safety thermostat for the rinse.
- Water consumption: 3 litres by rinse.
- Safety switch for hood opening.
- Electrical connection: 400 V - 3+N+T



Model	Reference	Production Dishes/h	Technical features (*)	Equipment (**)	Power KW	Dimensions mm	
AD-90	1210307406	800	1-C	S	11,10	675x675x1,400	
AD-120	1210307230	1.200	2-H	Z	17,70	675x675x1,400	

ELECTRIC PASS-THROUGH DISHWASHERS WITH DRAIN PUMP

Specific features:

Drain pump (90 W) and drainage cycle.



Model	Reference	Production Dishes/h	Technical features (*)	Equipment (**)	Power KW		Dimensions mm	
					Boiler	Total		
AD-120 B	1210307293	1.200	2-H	Z	12,00	17,79	675x675x1,400	

(*) TECHNICAL CHARACTERISTICS

- 1 : One wash pump for lower and upper systems, 590 W.
- 2 : Two independent wash pumps for lower and upper systems, 590 W each.
- C : Boiler with 6 kW power.
- H : Boiler with 12 kW power.

() EQUIPMENT**

- S : 1 basket CT-10 + 1 basket for dishes CP-16/18 + 2 cutlery containers.
- Z : 1 basket CT-10 + 2 basket for dishes CP-16/18 + 8 cutlery containers.

ADVANCE LINE DISHWASHERS

THE «ECO» TECHNOLOGY: «ECO» MODELS

The highest-capacity commercial pass through dishwasher (AD-120), as well as all compact models, modular conveyors and flight dishwashers are also available in a gas version.

These are our **ECO**, so-called on account of their **Economic** and **Ecological benefits**.

They are fitted with an **external gas generator for hot water** that affords the user numerous advantages:

Saving: up to 80% saving.

Ecology: Up to 100% reduction of contaminating waste emissions.

Speed: System time setting is reduced by 40%.

Versatility: Multi-gas: natural, butane, propane...

The saving made on an ECO dishwasher will see you recover your investment in less than three years.

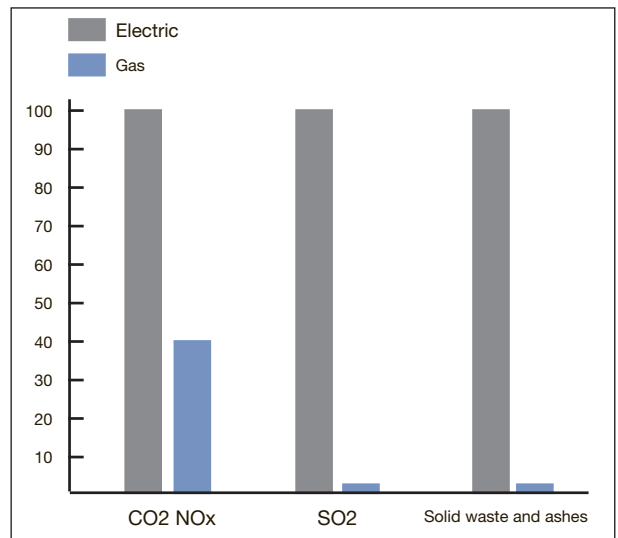

REDUCED ENERGY CONSUMPTION

For every therm (useful thermal energy unit) 3 primary energy units (electricity) are consumed, as compared with only 1.25 of primary energy units (gas).

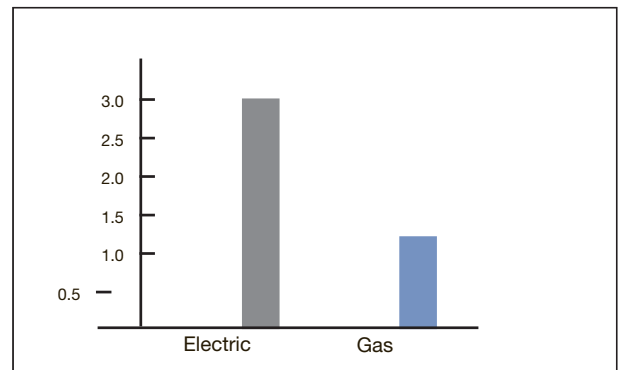

GAS PASS-THROUGH DISHWASHERS

The "ECO" models:

- More **ECONOMIC**
- More **ECOLOGIC**

Equipped with one **GA-20 hot water generator**, 20.000 kcal/h.
 Electronic control of water level and temperature.
 Rotating wash and rinse system.
 Wash cycles: 55", 75", 120", continuous washing position and stand-by position.
 Tank with 2.8 kW heating element. Tank capacity: 45 litres.
 Filters and trays in the wash tank.
 Two independent wash pumps for lower and upper systems.
 Pump for rinse water.
 Water consumption: 3 litres by rinse.
 Automatic rinse dispenser.
 Thermostatically adjusted:
 wash temperature 60 °C and rinse temperature 90 °C.
 Thermo stop system.
 Self diagnostic system.
 Anti - return protection.
 Safety thermostat.
 Digital display for rinsing and washing temperature.
 Safety switch for hood opening.

Equipment:

1 base basket CT-10, 2 baskets for dishes CP-16/18 and 8 cutlery containers.

Electric power: 4 KW - 230 V, 1+N+T.
 Gas power: 20.000 Kcal/h (23,25 KW).

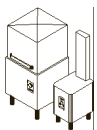

Model	Reference (*)	Production Dishes/h	Electrical connection	Electrical power - KW	Gas power		Dimensions mm	
					Kcal/h	KW		
AD-120 ECO	1210307305	1.200	230V-1+N+T	4,00	20.000	23,25	675x675x1,400	
AD-120 ECO-B	1210307397	1.200	230V-1+N+T	4,09	20.000	23,25	675x675x1,400	

(*) Note: with the code of the machine it is necessary to add the code of the generator **GA-20** : 1220300100 (LPG) or 1220300102 (GN), **that it is included in the price**

Warning:

If the water is very hard (over 10 HF / 6 HD) it is necessary to install a generator GA-20 D. It has an automatic descaling system. This is a chargeable extra. Contact with FAGOR.

AD-120-ECO B: Drain pump and drainage cycle. Power of the pump: 90 W.



AD-120-ECO with entry - exit tables

PREWASHING TABLES FOR ADVANCE PASS-THROUGH DISWASHERS

PRE WASHING TABLES FOR ADVANCE LINE

Manufactured for the pass-through dishwashers:
AD-90, AD-120, AD-120 ECO, FI-80 , FI-100

* Models with sink :

Sink dimensions: 450 x 450 x 250 mm.



*MFDB-1200 I model,
with guides, lower rack,
sink and shower tap*

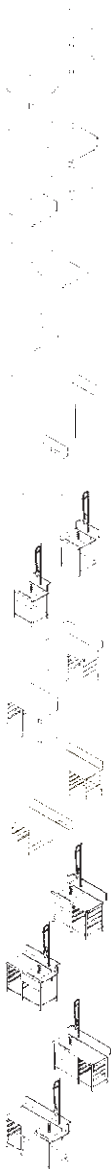

Model	Reference	Situation of the table	Equipment Features	Dimensions mm	
RIGHT TABLE	1210307515	RIGHT	- Lower rack	650x655x900	
LEFT TABLE	1210307516	LEFT			
RIGHT TABLE - REAR GUARD	1210307517	RIGHT	- Rear guard - Lower rack	650x655x900	
LEFT TABLE - REAR GUARD	1210307518	LEFT			
RIGHT TABLE - ECO	1210307519	RIGHT	- Hole for generator chimney	650x655x900	
LEFT TABLE - ECO	1210307520	LEFT			
RIGHT TABLE - ECO - R. GUARD	1210307521	RIGHT	- Rear guard - Hole for generator chimney	650x655x900	
LEFT TABLE - ECO - R. GUARD	1210307522	LEFT			
MFDB-700 D	2151502314	RIGHT	- Rear guard - Sink - Shower tap - Lower rack	700x700x900	
MFDB-700 I	2151502315	LEFT			
MLB-1200 D	2151502300	RIGHT	- Rear guard - Lower rack - Guides for baskets	1,200x700x900	
MLB-1200 I	2151502301	LEFT			
MLB-1200 ECO/D	2151502306	RIGHT	- Rear guard - Lower rack - Guides for baskets - Hole for generator chimney	1,200x700x900	
MLB-1200 ECO/I	2151502307	LEFT			
MFDB-1200 D	2151502316	RIGHT	- Rear guard - Sink - Shower tap - Lower rack - Guides for baskets	1,200x700x900	
MFDB-1200 I	2151502317	LEFT			
MFDB-1500 D	2151502302	RIGHT	- Rear guard - Sink - Shower tap - Lower rack - Guides for baskets	1,500x700x900	
MFDB-1500 I	2151502303	LEFT			

DELIVERY/SORTING TABLES FOR ADVANCE PASS-THROUGH DISWASH-

DELIVERY / SORTING TABLES FOR ADVANCE LINE

Manufactured for the pass-through dishwashers:
AD-90, AD-120, AD-120 ECO, FI-80 , FI-100

- Rear guard in all the models.
- Waste disposal.
- Space for the trash bin.
- Tables with sink built-in shower tap.

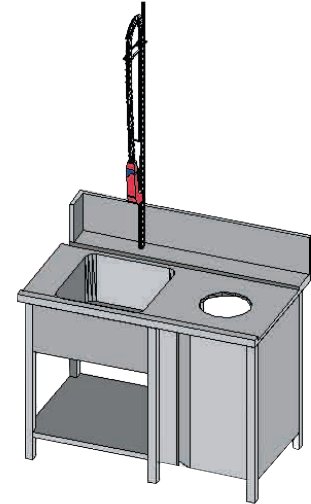

MFDP-1200-D model, with sink, shower tap, and closed space for trash bin.

Model	Reference	Situation of the table	Housing for bin	Equipment Features	Dimensions mm	
MLH-1200 D	2151502318	RIGHT	OPEN	- Lower rack	1,200x700x900	
MLH-1200 I	2151502319	LEFT				
MLP-1200 D	2151502320	RIGHT	With DOOR	- Lower rack	1,200x700x900	
MLP-1200 I	2151502321	LEFT				
MFDH-1200 D	2151502322	RIGHT	OPEN	- Sink - Shower tap - Lower rack	1,200x700x900	
MFDH-1200 I	2151502323	LEFT				
MFDP-1200 D	2151502324	RIGHT	With DOOR	- Sink - Shower tap - Lower rack	1,200x700x900	
MFDP-1200 I	2151502325	LEFT				
MFDH-1500 D	2151502326	RIGHT	OPEN	- Sink - Shower tap - Lower rack	1,500x700x900	
MFDH-1500 I	2151502327	LEFT				
MFDP-1500 D	2151502328	RIGHT	With DOOR	- Sink - Shower tap - Lower rack	1,500x700x900	
MFDP-1500 I	2151502329	LEFT				
MFDH-1800 D	2151502304	RIGHT	OPEN	- Sink - Shower tap - Lower rack - Guides for baskets	1,800x700x900	
MFDH-1800 I	2151502305	LEFT				
MFDP-1800 D	2151502330	RIGHT	With DOOR	- Sink - Shower tap - Lower rack - Guides for baskets	1,800x700x900	
MFDP-1800 I	2151502331	LEFT				

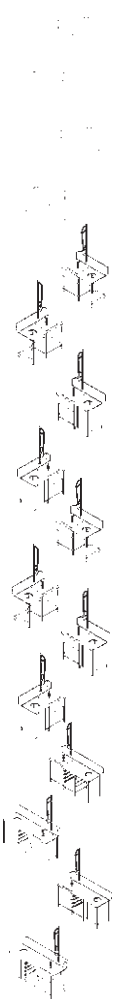

MFDH-1800-I model, with sink, shower tap, waste disposal, rear guard and guides for baskets



PREWASHING TABLES FOR ADVANCE COMPLET PASS-THROUGH DISWASHERS

PRE WASHING TABLES FOR ADVANCE COMPLET LINE

Manufactured for the pass-through dishwashers:
AD-90, AD-120, AD-120 ECO, FI-80 , FI-100



Model	Reference	Situation of the table	Equipment Features	Dimensions mm	
RIGHT TABLE	1210307515	RIGHT	- Lower rack	650x655x900	
LEFT TABLE	1210307516	LEFT			
RIGHT TABLE - REAR GUARD	1210307517	RIGHT	- Rear guard - Lower rack	650x655x900	
LEFT TABLE - REAR GUARD	1210307518	LEFT			
MLB-1200 AD-D	2151502350	RIGHT	- Rear guard - Lower rack - Guides for baskets	1,200x700x900	
MLB-1200 AD-I	2151502351	LEFT			
MFDB-1200 AD-D	2151502356	RIGHT	- Rear guard - Sink - Shower tap - Lower rack - Guides for baskets	1,200x700x900	
MFDB-1200 AD-I	2151502357	LEFT			
MFDB-1500 AD-D	2151502352	RIGHT	- Rear guard - Sink - Shower tap - Lower rack - Guides for baskets	1,500x700x900	
MFDB-1500 AD-I	2151502353	LEFT			
MFDB-1800 AD-D	2151502354	RIGHT	- Rear guard - Sink - Shower tap - Lower rack - Guides for baskets	1,800x700x900	
MFDB-1800 AD-I	2151502355	LEFT			

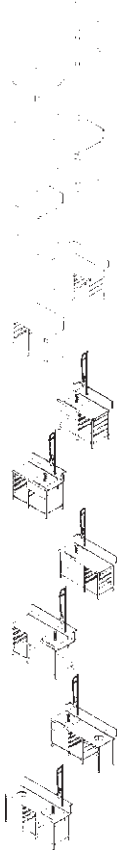

*MFDB-1200 AD-I model,
with guides, lower rack,
sink and shower tap*



SINKS WITH SPACE FOR DISHWASHER

Sink with draining board.
 Sink dimensions: 500 x 500 x 300 mm.
 Lower shelf under sink.
 Housing for the dishwasher under draining board.
 Space for dishwashers 600 x 600 mm,
 820÷850 mm high.
 Adjustable legs.



FBL-127 D

Model	Reference	Characteristics	Dimensions mm
FBL-127 D	2111123103 + 2111222120	Draining board and housing on the RIGHT	1,200x700x850
FBL-127 I	2111123104 + 2111222120	Draining board and housing on the LEFT	1,200x700x850

STAND FOR FRONT LOADING DISHWASHER

Space for baskets 500 x 500 mm.
 Capacity for 3 baskets height 110 mm.
 For the front loading dishwashers, except "72" models.



*AD-48 model
over stand*



Model	Reference	Characteristics	Dimensions mm
STAND	1210305185	Capacity for 3 baskets 500x500x110 mm	600x600x400

